

# MICROMAIN27

## Owner's Manual





## PRODUCT REGISTRATION

Please complete the product registration form for your Barefoot Sound studio monitors to be registered for warranty and product updates.

[CLICK HERE TO REGISTER NOW](#)



## PROTECT YOUR BAREFOOT MONITORS

We will keep the model number and date of purchase of your new Barefoot Sound product on file to help you refer to this information in the event of an insurance claim such as loss or theft.

<u>Contents</u>	page
Description	01
Warnings! (please read carefully)	02
Inputs and Controls	03
Connections	04
Startup	04
Signal Flow Diagram	05
Protection	06
Positioning	06
MEME™ Voicing	08
Force Cancellation	09
Maintenance	10
Handle Attachment	10
Frequency Response	11
Specifications	12
Drawings	13
Warranty	14
Appendix : Stand Mounting	15

## 1. Description

The MicroMain27 Gen2 is a 3.5-way active loudspeaker capable of nearfield, mid-field and far-field operation. The five drive units are all housed in sealed enclosures. The DSP controlled four-way power amplifier module can deliver 500 Watts continuously. The system accepts either analog or 24 bit/192 kHz digital audio signals. Cutting edge MEME™ (Multi Emphasis Monitor Emulation™) technology enables the MicroMain27 Gen2 to model the frequency, phase and transient responses, dynamic compression, distortion signature and overall translation characteristics of classic studio monitors.



## 2. **Warnings!**

The Mains Voltage Select switch (VAC Select) on the rear panel must be in the 230V position for AC power line voltages over 132 VAC. Connecting the power cord to AC power line voltages over 132 VAC while the VAC Select switch is in the 115V position will damage the amplifier. Such damage is NOT covered under warranty.

**Rear panel VAC Select switch location**

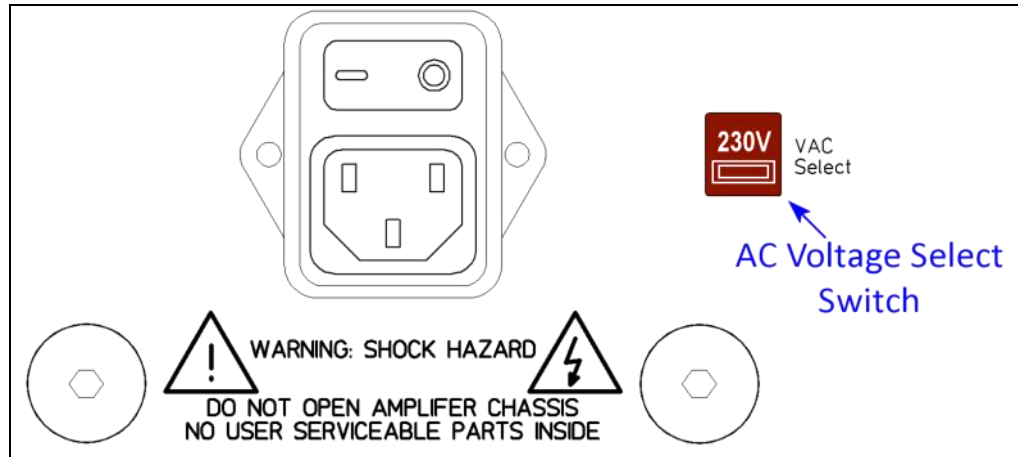

**Please read and follow the safety information below:**

- Do not remove the rear amplifier panel. There is a risk of electric shock. No user serviceable parts are inside. Please refer service issues to a qualified technician.
- Do not operate this device with an ungrounded mains power cable or a mains connection that is ungrounded. This may result in personal injury.
- Do not place open flames such as lighted candles on or near this device .
- Do not expose this device to water, rain or high humidity. Do not place objects filled with liquids, such as vases, on or near this device.
- This speaker requires adequate airflow to maintain proper cooling. Do not obstruct airflow around the speaker. Do not run the speaker upside down (mains power connector on top).
- Do not operate this device in ambient temperatures above 30°C (85°F). Over-temperature may cause device failure.

**Caution!** This speaker is capable of producing sound pressure levels in excess of 85dB which may cause permanent hearing damage. Always verify that input signal levels are attenuated before powering on the speaker.

### 3. Inputs and Controls

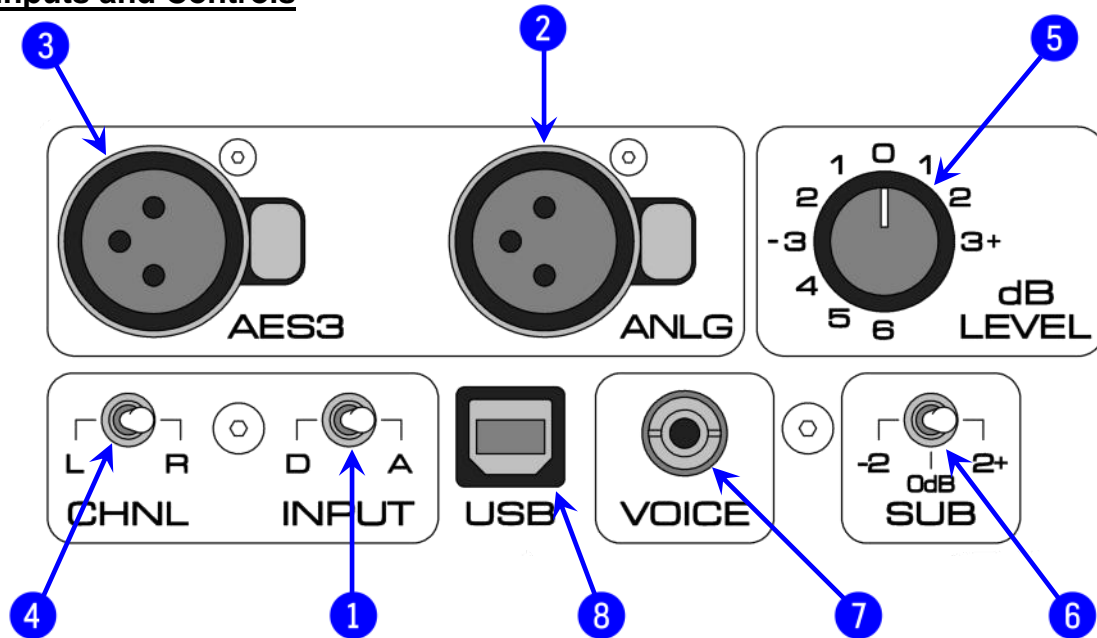

1. [INPUT] Toggle switch selects between the analog (A) and digital (D) inputs.
2. [ANLG] XLR connector is designed to receive analog balanced line level audio signal from sources such as preamplifiers, sound cards, monitor controllers and mixing consoles. Pin 1 is tied to chassis ground. Pins 2 & 3 are fully floating differential inputs. Pin 3 must be referenced to ground for single ended input signals. The analog signal is converted to 24bit/192kHz digital audio via a precision, ultra-high-fidelity analog to digital converter section inside the MicroMain27 Gen2.
3. [AES3] XLR connector is designed to receive digital AES3 standard audio signal from sources such as sound cards and digital audio workstations (DAW). The digital signal must be attenuated at the source ("In The Box"). **Caution:** Non-attenuated digital audio will produce very high sound pressure levels that can potentially damage your hearing and/or the speakers. Each AES3 XLR carries both left and right audio signals. For stereo or multiple speaker operation the monitor output signal must be assigned to two or more AES3 output XLRs within the DAW. Otherwise, a passive AES splitter or an active AES distribution amplifier is required to deliver signal from a signal from a single AES output XLR. Use the CHNL switch on the back of each speaker to select appropriate left or right audio signal from the stereo AES signal.
4. [CHNL] Toggle switch selects between the left (L) or right (R) channel coming from the AES3 data signal. This switch is only active when the INPUT toggle is in the (D) position.
5. [LEVEL] Eight position rotary switch adjusts the level of both the Analog and Digital inputs in precise 1dB increments from +3dB to -6dB.
6. [SUB] Three position toggle switch adjusts the level of the subwoofers from 0dB to +2dB or -2dB.
7. [VOICE] 3.5mm stereo phone jack for connection to MEME™ Selector Switch. See Section 9 for MEME™ settings and connection details. The default setting with no switch connected is Flat.
8. [USB] The universal serial bus connector is for factory adjustments and calibrations. This connector is NOT an audio input.

## 4. Connections

### Analog:

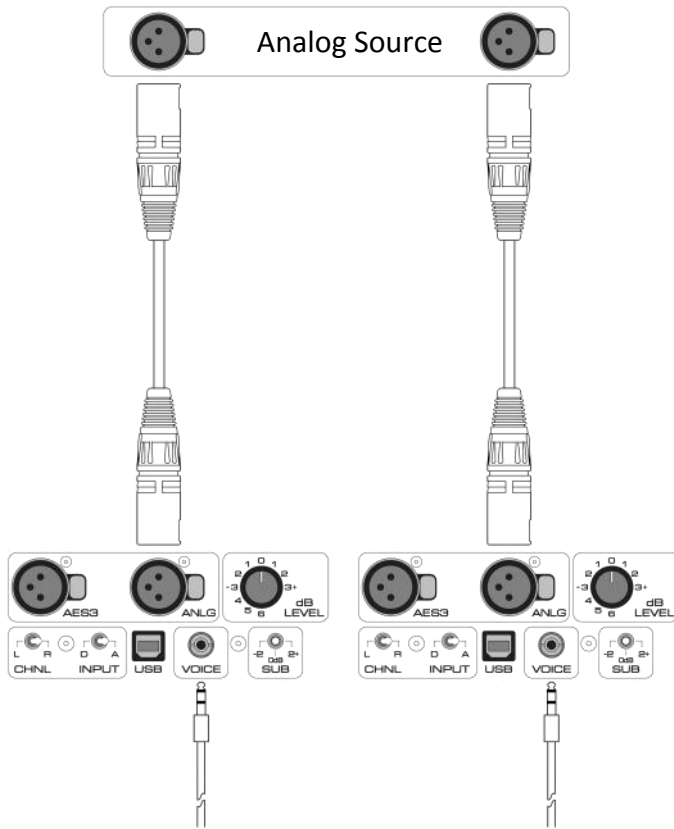

### Digital:

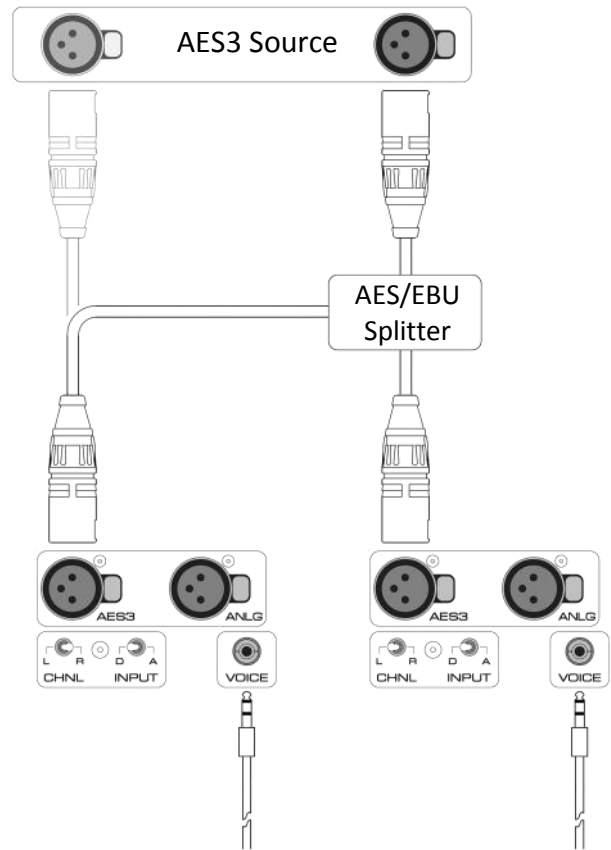

\* See Section 9 for Voice connection details.

## 5. Startup

1. Verify that the AC Voltage select switch on the rear panel is in the correct position for the AC voltage in your facility (see warnings on previous page for details) then plug in grounded mains power cable.
2. Set Input toggle switch to either analog (A) or digital (D) depending on the type of source signal you are using. For digital signals also set the Channel toggle switch to left (L) or right (R) in accordance with the speaker position.
3. Ensure that the audio signal is fully attenuated (AES3 signal requires digital attenuation).
4. Power on the speaker with the rocker switch located on the rear panel above the mains connector. The LED indicator on the front of the speaker will illuminate Red for a couple of seconds then turn Aqua.
5. Turn up the audio signal and enjoy!

## 6. Signal Flow Diagram

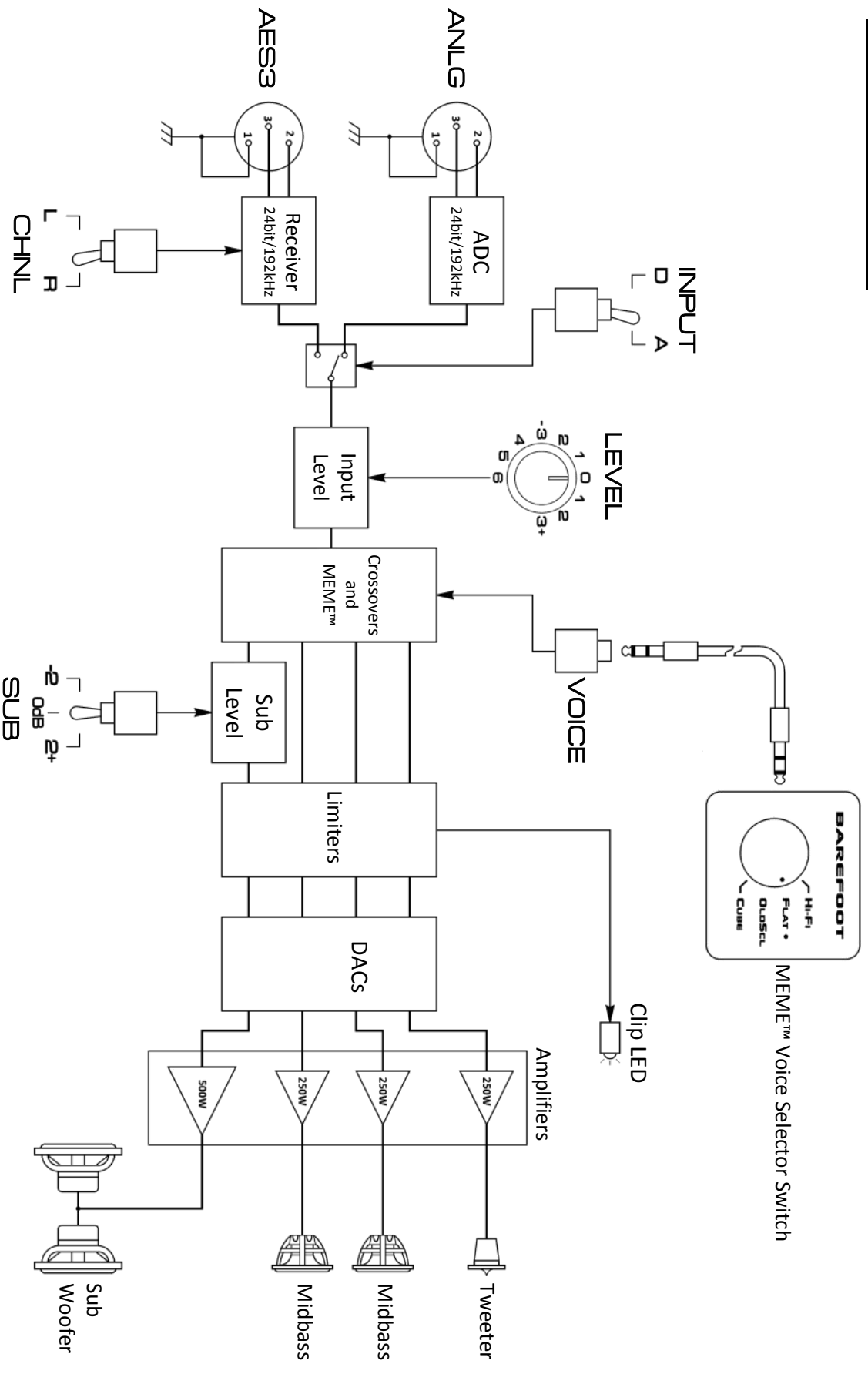

## **7. Protection**

### **Limiters**

#### **Peak Limiter**

The Subwoofer, Midbass and Tweeter channels have individual Peak Limiters designed to protect each driver from high amplitude, short duration audio input signal spikes that might cause damage due to over excursion of the voice coil. These limiters are implemented digitally within the DSP in such a manner that they have zero effect on the audio signal below their thresholds. The front LED indicator light will flash RED when a Peak Limiter on any of the driver channels is triggered. The duration of such events is only a fraction of a second. Therefore, the LED flash may appear pink or orange as the eye naturally blends the normally aqua-blue color of the LED with the red.

#### **RMS Limiter**

The Subwoofer, Midbass and Tweeter channels have individual RMS Limiters designed to protect each driver from long duration, high amplitude audio input signals that might cause thermal damage due to the voice coil. These limiters are implemented digitally within the DSP in such a manner that they have zero effect on the audio signal below their thresholds. The front LED indicator light will flash RED when a RMS Limiter on any of the driver channels is triggered.

**Caution:** Signals large enough to trigger any of the limiters can generate very high sound pressure levels that may result in permanent hearing damage.

### **Over Current**

In the event of a large audio input signal that might damage the amplifiers or power supply due to current overload, the power supply is designed to enter into Over Current protect mode. This state typically results from a large, broadband input signal burst that flat lines the limiters on all four channels simultaneously. While the fault persists the amplifier power rails shut down, the speaker goes quiet, and the front panel LED turns red. Once the audio input signal is turned down the speaker should reboot within a few seconds. If the speaker fails to reboot or the LED light goes out completely, disconnect the audio input cable and power cycle the speaker. Verify the signal level is attenuated before reconnecting audio input cable.

**Caution:** Signals that cause Over Current protection to trigger can generate very high sound pressure levels that may result in permanent hearing damage.

## **8. Positioning**

The acoustic center of the MicroMain27 Gen2 is located at the center of the tweeter. The MM27 Gen2 is designed to work equally well as a nearfield or mid-field monitor. The minimum recommended listening distance is 1 meter (39.4"). While speaker positioning can sometimes be dependent on the nature of the room, a good starting point is to create an equilateral triangle between the two speakers and the listening position. The speakers should be angled inward approximately 30 degrees so the tweeter axes aim towards the listener's ears, crossing a few inches behind the head.

When the speakers are standing vertically, the "Barefoot" text on the front faceplates of both speakers should be on top. When the speakers are turned on their sides to the horizontal orientation, the "Barefoot" text on the front faceplates should be towards the outside. This places the 'bottom' midbass drivers towards the center of the stereo field.



**Example:** Symmetrical stereo arrangements.

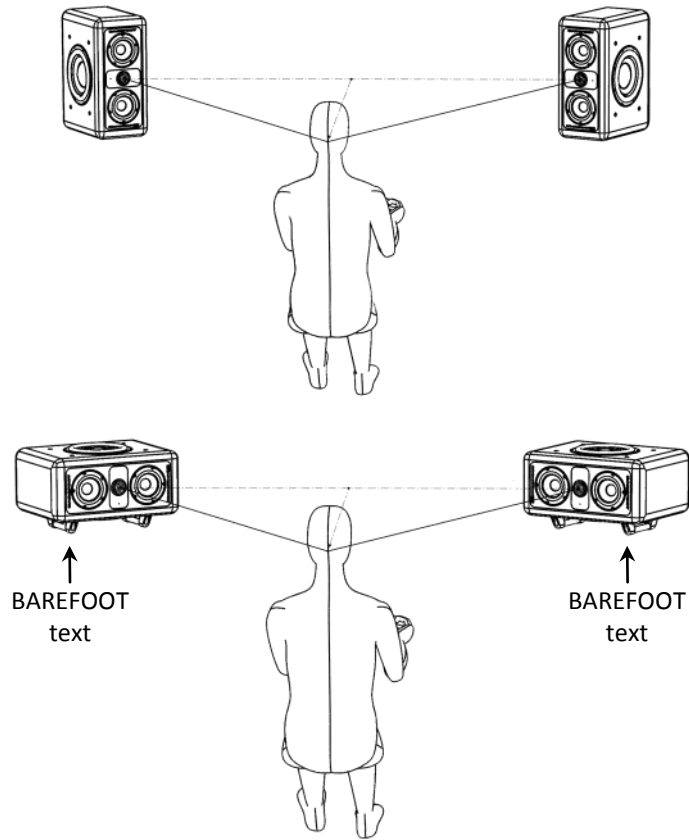

## Cooling

While the Hypex amplifier modules that drive the MicroMain27 Gen2 are a very efficient, the speaker still generates a significant amount of heat that must be dissipated. This heat is transmitted to the air via the rear amplifier plate, heat sink and the subwoofer cones. In order to ensure proper airflow, a minimum of 5" (127mm) clearance should be maintained between the speaker and any large obstructions. An ambient temperature below 30°C (85°F) should be maintained. Over-temperature may cause speaker to overheat and shut down.

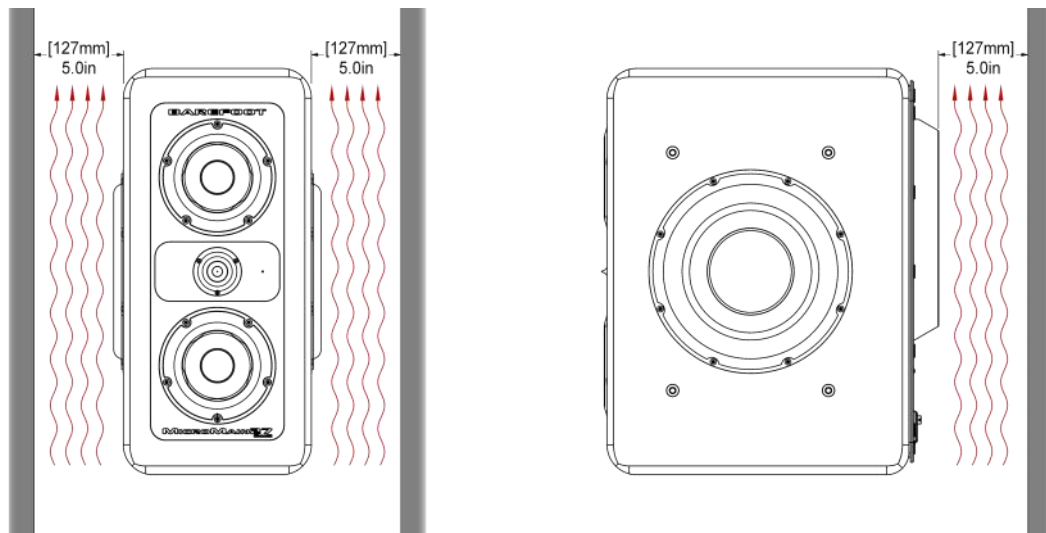

## 9. MEME™ (Multi Emphasis Monitor Emulation)

With the MM27 GEN2, you can box up your secondary reference monitors for good. Despite the advantages of high-resolution monitors, many engineers still rely on their NS10s and mix cubes as secondary references. These speakers have long traditions and people find them familiar and useful for focusing in on certain aspects of their mix. However, it's also a fact that crowding your console with those extra boxes degrades the sound field of the primary reference monitors. Not to mention, they are no longer manufactured, need amplifiers, require cable runs, and consume more studio space. To offer an elegant solution, while streamlining the studio at the same time, the MM27 GEN2 has the ability to sound and translate like those classic speakers.

### Voices:

- FLAT** - Optimal setting for accuracy, transparency and outstanding translation. Setting has a flat frequency response and extremely fast transient response. This is the default voice when the Voice Selector Switch is not connected.
- HI-FI** - While it does not emulate any one speaker in particular, this setting is indicative of “hi-fi” in the colloquial sense of the term. The midrange is a bit scooped and highs are little accentuated. The bass response is altered to have less damping yielding a hybrid character somewhere between the fast, tight, articulate sound of a sealed cabinet and the slower, fatter sound of a ported speaker. A touch of tube amplifier warmth has also been added. The result is a sweeter more forgiving sonic character.
- OldScl** - This setting emulates the frequency, phase and transient response, along with the dynamic compression and distortion signature of the NS10M.
- CUBE** - This setting emulates the frequency, phase and transient response, along with the dynamic compression and distortion signature of classic mix cubes.

### MEME™ Voicing Frequency Responses:

dB SPL at 1 meter, -15 dBV input (attenuator = 0db)

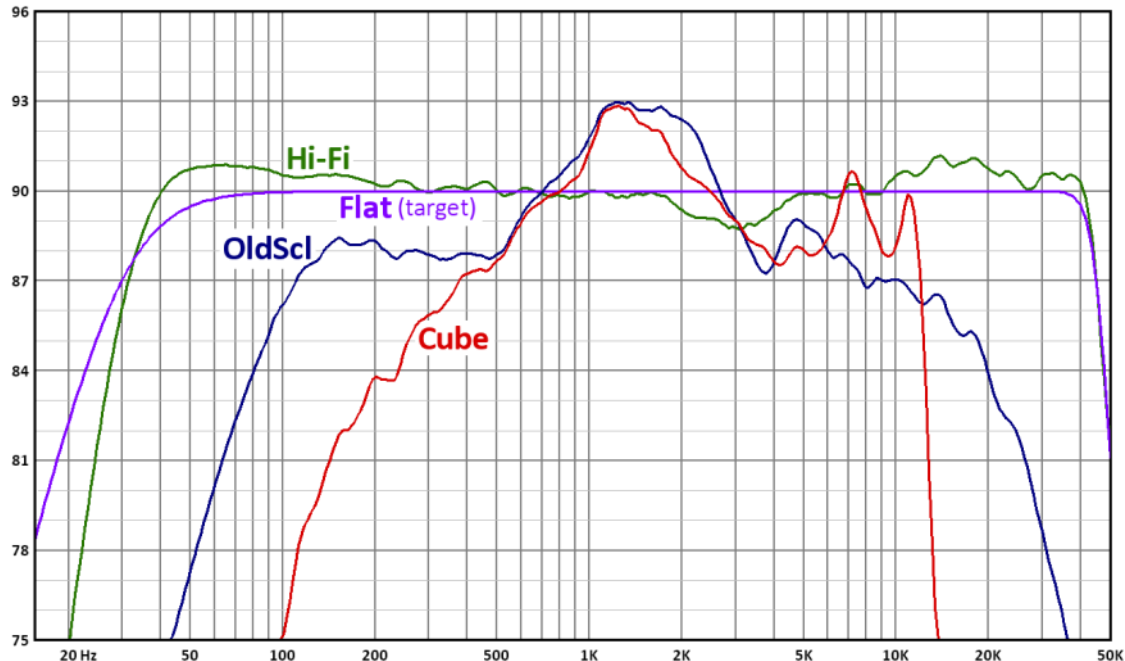

### MEME™ Voice Selector Connection:

The MEME™ Voice Selector switch box is connected to the Voice jack of the speaker via any standard 3.5 mm stereo phone cable. The included 6-way splitter can be used to control the Voice Emulation of up to 5 speakers. Furthermore, the input impedance of the Voice jack is very high. So, additional splitters can be daisy chained in order to control virtually any number of speakers with the MEME™ Voice Selector switch.

Caveat: Plugging the speaker into different mains outlets can potentially cause erratic behavior in the MEME™ control. The safety grounds of different outlets can sometimes have ground potential differences of a few volts or more. The resulting voltage spread between the grounded chassis of various speakers can cause the MEME™ control inputs to read incorrect settings or become unstable. Care must be taken with the studio mains power and safety ground layout. If this is a concern, please consult a qualified electrician.

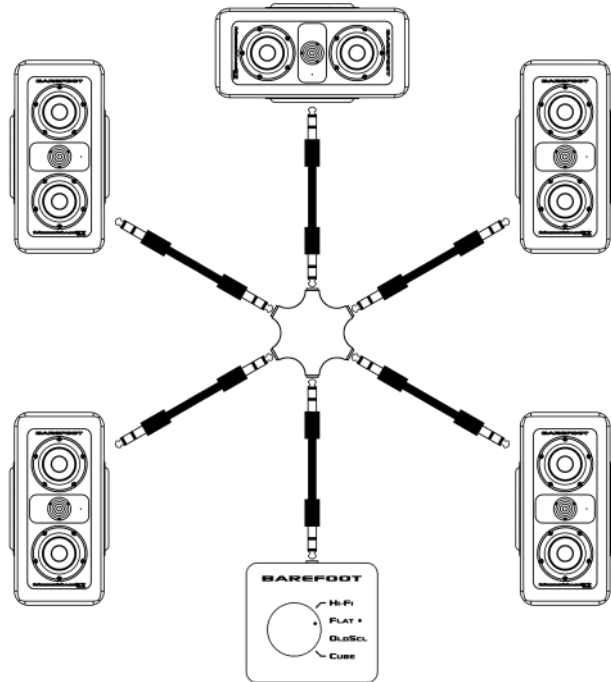

Example: 5 channel MEME™ Voice control layout.

## 10. Force Cancellation

Cabinet vibrations are a significant source of distortion and coloration in most loudspeakers. The primary mechanism that generates cabinet vibrations is simple Newtonian action and reaction. As the driver motor (magnet and voice coil) forces the cone to move back and forth in order to generate sound, the cone exerts an equal and opposite force on the motor. This force is transmitted through the driver frame to the cabinet, vibrating the cabinet walls and coloring the sound emitted by the cone. This effect is most especially prevalent in the low frequency drivers where the cone motion is greatest.

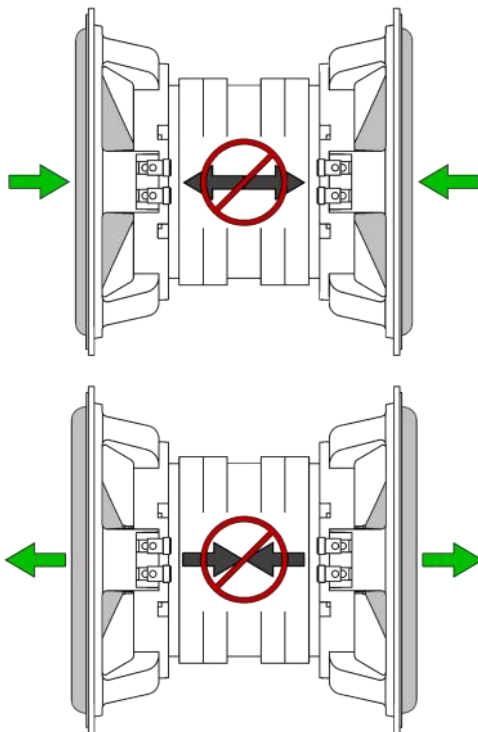

While, the MicroMain27 Gen2 is built with a massive and well braced cabinet, we also tackle the problem at its source by eliminating vibrations before they even begin. This is achieved through our innovative force cancellation design. The low frequency drivers are mounted on opposing sides of the cabinet and their motors are locked together. As the cones are driven in and out in opposite directions the forces exerted on the motors cancel one another. The vibrations never make it to the cabinet because they are not allowed to develop in the first place.

This layout has further benefits. Since the drivers are locked together, the motors and frames function as a massive internal metal cabinet bracing. And because the wavelengths generated by the subwoofers are much larger than the speaker cabinet dimensions, the subs radiate as if they were a single point source located on axis with the tweeter.

## 11. Maintenance

Exterior surfaces of this product may be cleaned using a non-abrasive lint-free cloth lightly dampened with water. Disconnect the mains power cable when cleaning to avoid risk of electric shock. Do not use alcohol-based cleaners.

Driver active surfaces such as diaphragms and surrounds may be cleaned using dry soft bristle brushes. Driver diaphragms are very delicate and easily damaged. So proceed with great care. Clean new sable artist brushes or cosmetic brushes work well for this task. Gently brush dust away from the surface starting at the center of the driver diaphragm and moving radially outward. Avoid applying inward pressure to the driver diaphragm.

Repairs, maintenance, or other servicing of this product when its interior compartment is exposed should only be performed under specific advice from Barefoot Sound by a qualified technician or by the Barefoot Service Center. There are no user-serviceable parts inside this product.

## 12. Handle Attachment

Each MM27 Gen2 is supplied with two handles. The handles are useful for lifting and positioning the speaker. The handles can also be used as base "skids" for mounting the speaker in the horizontal orientation.

**Caution:** the handles should never be used to suspend the MM27 Gen2.

Attach the handle by positioning it over the mounting holes on the side of the speaker cabinet. Insert the 5/16"-18 x 1.25" flat head screws and tighten using the 3/16" hex key. **Do not over tighten!** Over tightening can strip out the threaded cabinet inserts and/or damage the finish of the cabinet. Such damage is not covered under warranty.

A good way to ensure you do not over tighten the screws is to put the long end of the hex key into the screw and turn it using the short end. Tighten the screw using no more force than you can apply to the short end of the hex key while holding it in the tips of your thumb and index finger.

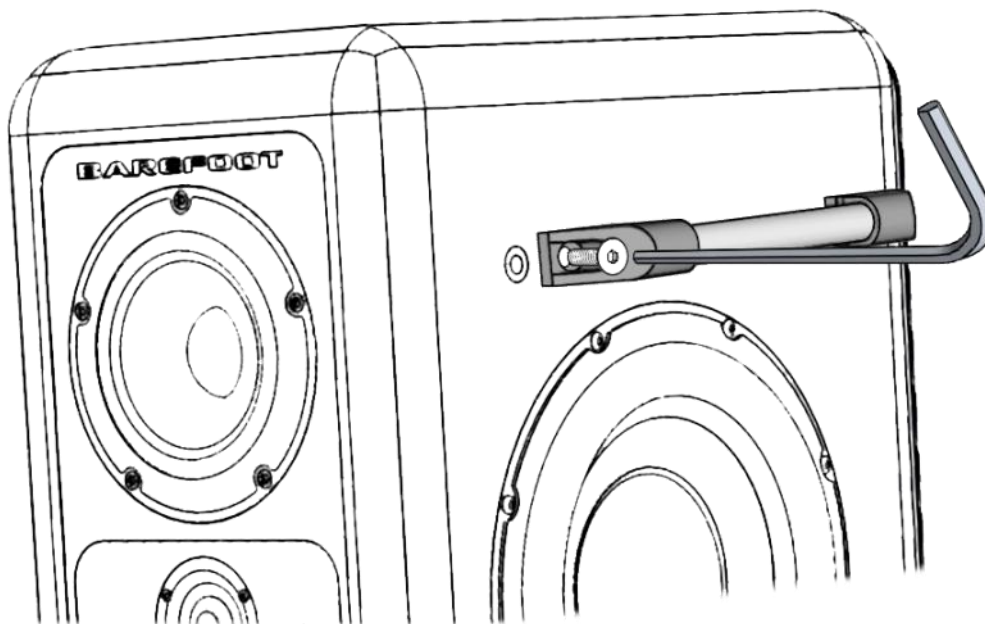

### 13. MicroMain27 Gen2 Frequency Response

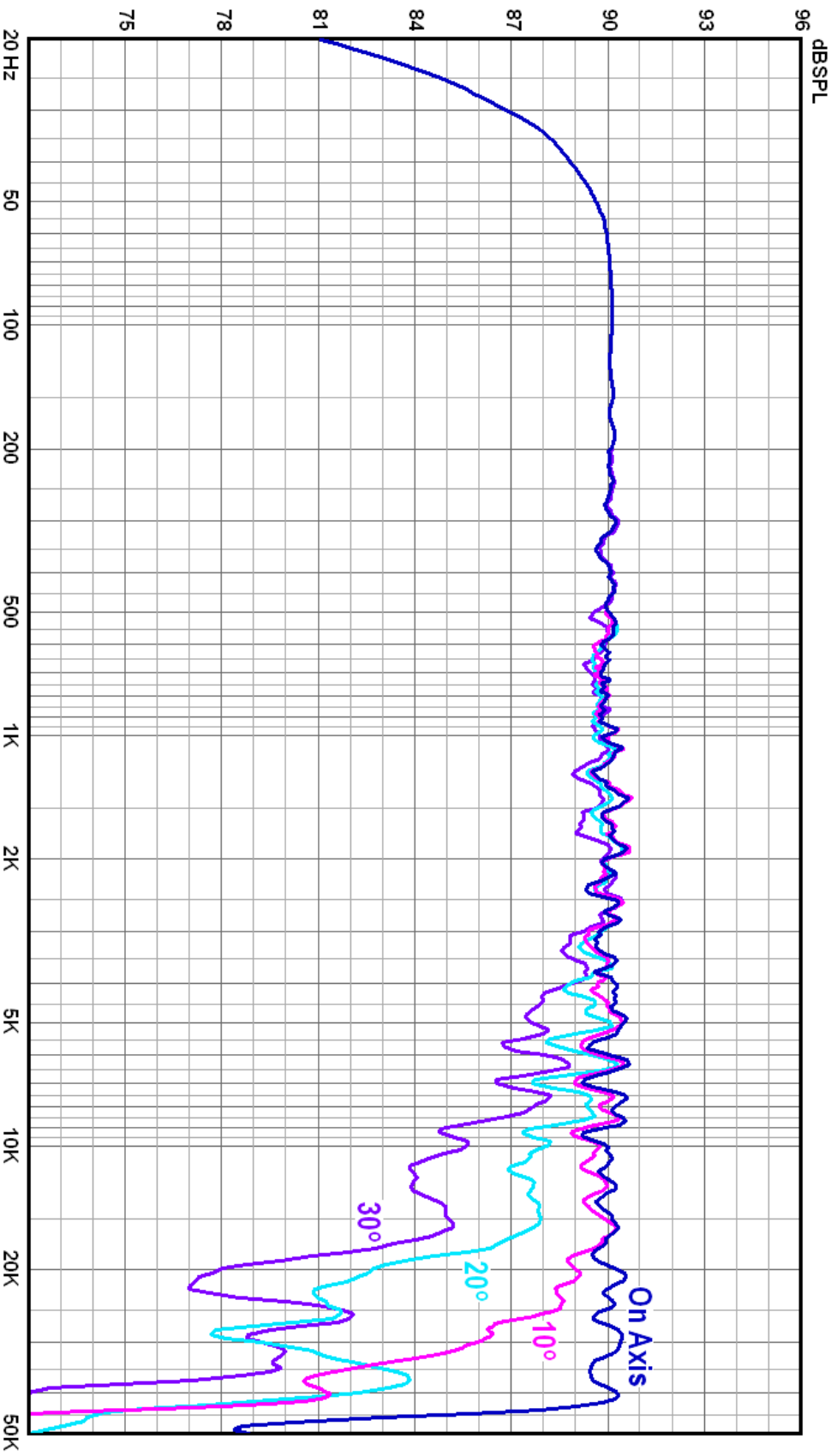

dB SPL at 1 meter, free field, -15 dBV input (attenuator = 0db)

## 14. Specifications

<b>Analog Input</b>	XLR female, Pin 1 ground, Pin 2 positive, Pin 3 negative Input Impedance = 100k Ohms Input Sensitivity (1m) = 90 dB @ -18 dBV (pass band)
<b>Analog to Digital Conversion</b>	Word Length: 24 bit Sample Rate: 192 kHz Oversampling = 128x Signal/Noise $\geq$ 125 dB
<b>Digital Input</b>	XLR female AES/EBU (AES3 standard) Input Impedance = 110 Ohms Word Length: 16,18, 20 or 24 bit Sample Rate: 32 kHz to 192 kHz Signal/Noise $\geq$ 133 dB
<b>Frequency Response</b>	30 Hz - 45 kHz (+/- 3 dB ), 40 Hz - 40 kHz (+/- 1 dB )
<b>Bass Response</b>	-3 dB @ 30 Hz Q = 0.707 Slope = 12 dB/octave
<b>Cabinet</b>	32 liters total internal volume Sealed subwoofer and midbass enclosures Machined aluminum baffle plate Aluminum subwoofer frames function as lateral cabinet bracing Long fiber wool acoustic damping throughout
<b>Crossover Frequencies</b>	100 / 600 / 3000 Hz
<b>Tweeter</b>	1" ring radiator with Advanced neodymium motor Rear waveguide chamber Amplifier: 250W Hypex
<b>Midbass 1</b>	5.25" poly/paper cone with Advanced neodymium motor +/- 5 mm linear excursion Amplifier: 250W Hypex
<b>Midbass 2</b>	5.25" poly/paper cone with Advanced neodymium motor +/- 5 mm linear excursion Amplifier: 250W Hypex
<b>Subwoofers</b>	2 x 10" aluminum cone with low distortion motor +/- 13 mm linear excursion Amplifier: 500W Hypex
<b>Power</b>	Mains Voltage Input: 115 or 230 VAC selectable Idle Power Consumption = 30W Maximum Power Consumption = 650 W
<b>Weight</b>	Speaker: 68 lbs each (31 kg) Shipping: 80 lbs each (36 kg)
<b>Dimensions HxWxD</b>	Cabinet: 20.5 x 9.5 x 15.5 inches (521 x 241 x 394 mm) Overall: 20.5 x 10.5 x 17.4 inches (521 x 267 x 442 mm)

### 13. Drawing

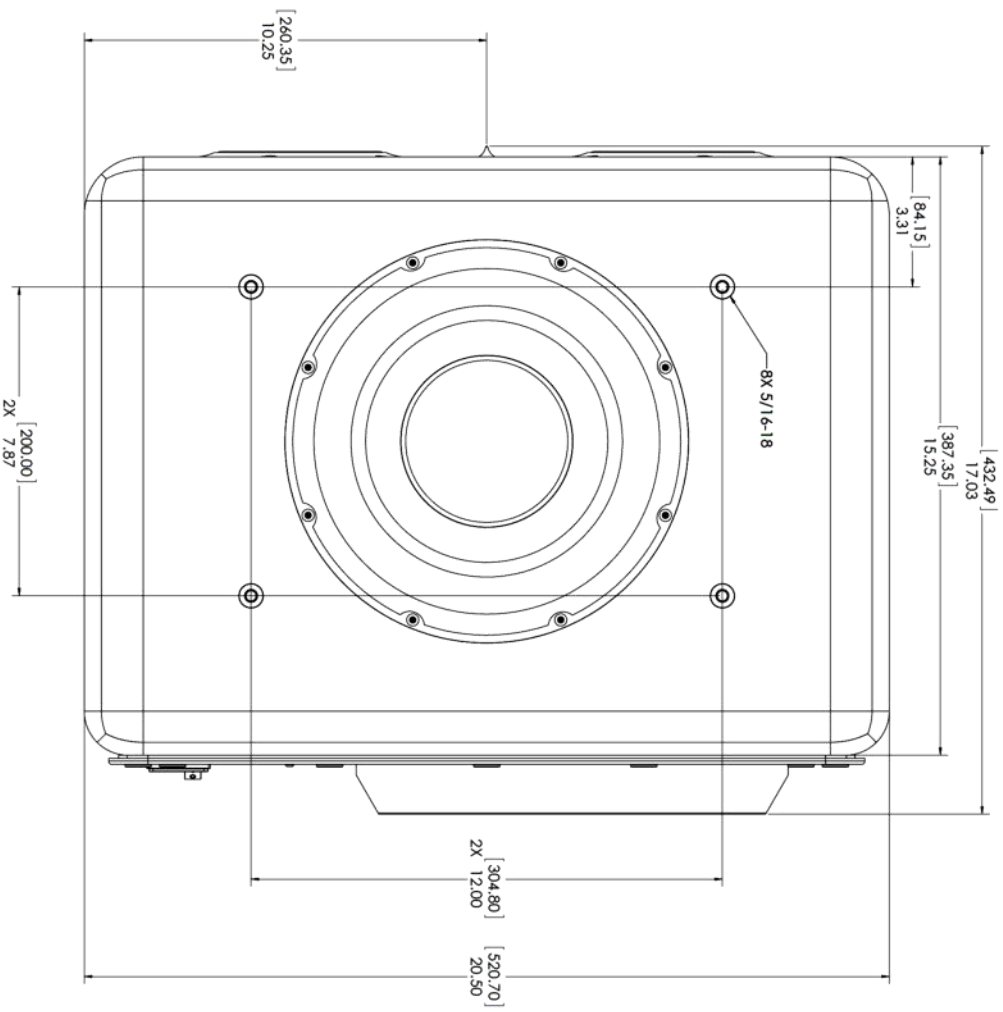
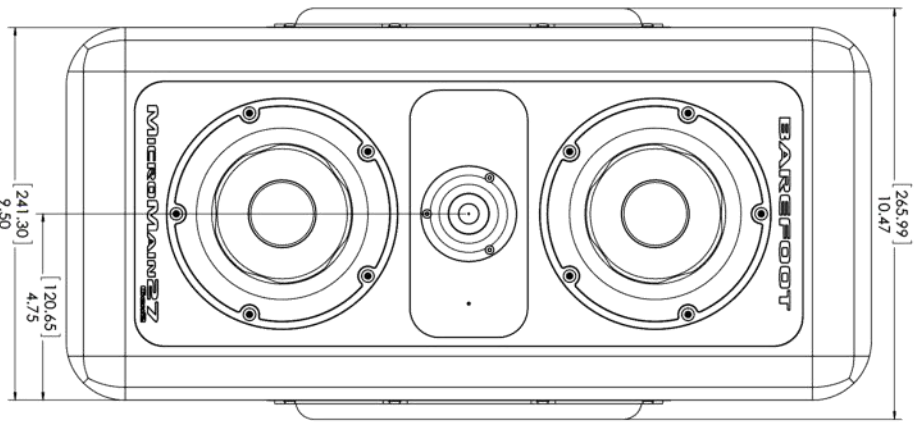

## **14. Warranty**

This product is under limited warranty as described in the following conditions. The warranty period commences on the date of purchase from the authorized dealer. Barefoot Sound reserves the right to request your original purchase receipt as proof of the date of purchase. The warranty follows the product and is transferable to any subsequent owner(s) as long as a copy of the original purchase receipt from the authorized dealer can be provided.

Electronic components and cabinetry of the product are warranted for a period of three (3) years against manufacturing defect, covering parts and labor for necessary repairs.

Moving speaker components are warranted for a period of one (1) year against manufacturing defect.

The manufacturer's warranties are limited to physical defects in the materials, parts and workmanship used in making the product. Misuse, incorrect installation, connection or handling, repairs or modifications performed by unauthorized persons, abnormal conditions, deliberate abuse, damage due to accidents such as power surges, water, fire, or any other are excluded from any warranty claims. In addition, faulty or unsuitable ancillary equipment, accessories, or options are fitted at owner's risk.

Barefoot Sound warrants all service repairs and replacements for 180 days from the date of return to the customer/owner. This warranty specifically excludes unrelated additional defects or failures. Otherwise the same general provisions of the limited product warranties apply.

### **Technical Support and Service**

For warranty service and assistance, contact the original authorized dealer/distributor to arrange for return and/or repair of the product. Barefoot Sound will strive to satisfy all service requests in the fastest manner possible. Under the warranty, Barefoot Sound will repair, or at its discretion, replace the product at no charge, provided it is returned (postage paid) to an authorized Barefoot Sound service center. Any shipping or duties incurred are the customer's responsibility. Products should be returned suitably packaged to protect from shipping damage, or in their original packaging. Barefoot Sound shall be the sole and final authority to determine the validity of all warranty issues. All non-warranty repairs for current products will be charged according to the service repair pricing schedule. Repair prices will either be based on a flat fee for repair or replacement, or will be estimated depending on the repair deemed necessary.



## Appendix: Sound Anchors Stand Vertical Mounting Procedure

Note: There are two variants of Sound Anchor stands designed for the MM27. Earlier models have 1" thick tubular steel mounting brackets. These require 2" long 5/16"-18 screws to fit the MM27 Gen2. Newer Sound Anchor stands have 0.5" thick solid aluminum mounting brackets. These require 1.5" long 5/16"-18 screws to fit the MM27 Gen2. Please check the size of the mounting screws supplied with your Sound Anchor stands to insure a proper fit. Prior to mounting the stands, turn the screws into the side of the MM27 Gen2 by hand. M8 and 5/16-18 screws are very similar in size. Incorrect size screws will go in a few turns then begin to lock up. If this occurs, contact Sound Anchors, Barefoot (info@barefootsound.com) or your dealer for the correct size screws.

1. Test the length of the screws by removing the mounting bracket from the stand and placing it on the side of the speaker cabinet. Line up the mounting holes, insert the screws and finger tighten. The screws should engage the threaded inserts and begin to pull the bracket snug against the speaker cabinet. If the bolts are too long and bottom out before the bracket is snug against the speaker cabinet, STOP. You may have the wrong size bolts. Contact Sound Anchors, Barefoot (info@barefootsound.com) or your dealer for the correct size screws.
2. Secure the speaker mounting bracket to the stand at desired height.
3. Attach MM27 Gen2 handles to the side of the cabinet opposite to the side the mounting bracket will attach to. Then set the speaker horizontally on the floor.
4. Tilt stand down and line up the mounting bracket holes with the cabinet bolt holes.

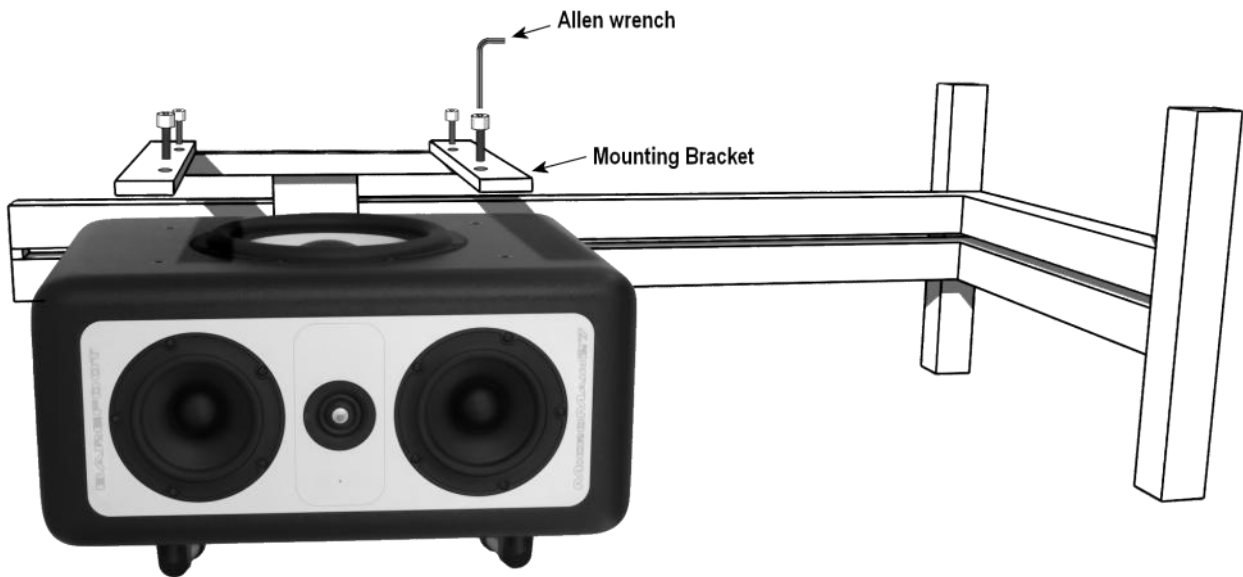

5. Insert bolts and tighten until the mounting bracket is snug against the speaker cabinet. **Do not over tighten!**

A good way to ensure you do not over tighten the screws is to put the long end of the hex key into the screw and turn it using the short end. Tighten the screw using no more force than you can apply to the short end of the hex key while holding it in the tips of your thumb and index finger.

6. Carefully tilt the entire speaker and stand assembly back up so it stands vertically. This step may require assistance because the speaker and stand are very heavy.

## Limited Warranty

BAREFOOT SOUND warrants electronic components and cabinetry for a period of three (3) years against manufacturing defects, covering parts and labor for necessary repairs. Moving speaker components such as tweeters, midranges and woofers are warranted for a period of one (1) year against manufacturing defects.

Shipping fees incurred from returns for under-warranty service in the first 30-days will be paid by BAREFOOT SOUND. All shipping fees both to and from BAREFOOT SOUND following this 30-day period must be paid by the customer. All returns, both during and following the 30-day period, must be affected via the Procedures for Obtaining Warranty Service described below.

BAREFOOT SOUND makes no other warranty, either express or implied, including but not limited to implied warranties of merchantability, fitness for a particular purpose, or conformity to any representation or description, with respect to this product other than as set forth below. BAREFOOT SOUND makes no warranty or

representation, either express or implied, with respect to any other manufacturer's product or documentation, its quality, performance, merchantability, fitness for a particular purpose, or conformity to any representation or description.

Except as provided below, BAREFOOT SOUND is not liable for any loss, cost, expense, inconvenience or damage that may result from use or inability to use the product. Under no circumstances shall BAREFOOT SOUND be liable for any loss, cost, expense, inconvenience or damage exceeding the purchase price of the product.

The warranty and remedies set forth below are exclusive and in lieu of all others, oral or written, expressed or implied. No reseller, agent or employee is authorized to make any modification, extension or addition to this warranty.

---

## Warranty Conditions

The above Limited Warranty is subject to the following conditions:

This warranty covers only normal use of the product. BAREFOOT SOUND shall not be liable under this warranty if any damage or defect results from (i) misuse, abuse, neglect, improper shipping or installation; (ii) disasters such as fire, flood, lightning or improper electric current; or (iii) repairs, service or alteration by anyone other than an authorized BAREFOOT SOUND representative: (iv) damages incurred through incorrect connection or handling, abnormal conditions, high humidity, deliberate abuse, power surges, water spills, or any other accidents.

You must retain your bill of sale or other proof of purchase to receive warranty service.

No warranty extension will be granted for any replacement part(s) furnished to the purchaser in fulfillment of this warranty.

To return a defective product, please contact our Customer Service Department at [www.barefootsound.com/service-request/](http://www.barefootsound.com/service-request/) for a Return Merchandise Authorization (RMA) number and follow the Return of Products Instructions below. Returns will not be accepted without an RMA.

## Procedures for Obtaining Warranty Service

### RMA (Returning Merchandise Authorization) Policy:

If repairs are required, the customer must obtain a RMA number and provide proof of purchase. RMA and services are rendered by BAREFOOT SOUND only. Any shipping costs after 30 days (starting from the original date of purchase) on any item returned for repair is the customers' responsibility. All returned parts must have a RMA number written clearly on the outside of the package along with a letter detailing the problems and a copy of the original proof of purchase. No COD packages will be accepted. No package will be accepted without a RMA number written on the outside of the package.

1. If the product must be repaired, a RMA number (Return Merchandise Authorization Number) will be issued for shipment to our repair department. Please follow the instructions given by BAREFOOT SOUND technical support staff to ship your product. BAREFOOT SOUND will not accept any shipments without a RMA number.

2. Pack the product in its original box or a well-protected box, as outlined by BAREFOOT SOUND Customer Service. BAREFOOT SOUND will not be responsible for shipping damage/loss of any product not shipped in its original packaging. BAREFOOT SOUND will not be responsible for shipping damage/loss of any product outside the original 30-day paid service period. It is very important that you write the RMA number clearly on the outside of the package. Ship the product with a copy of your bill of sale or other proof of purchase, your name,

address, phone number, email address, description of the problem(s), and the RMA number you have obtained to the address provided to you by BAREFOOT SOUND Customer Service.

3. Upon receiving the product, BAREFOOT SOUND will repair or replace your product (at BAREFOOT SOUND's discretion) and will ship it back to you within a timely manner (dependent on parts availability) via FedEx.

4. Cross-exchange (Parts only): You will need to provide a valid credit card number as a deposit guarantee when the RMA number is issued. Once approval has been obtained on your credit card, the part(s) will be shipped FedEx. You will need to ship defective part(s) back to BAREFOOT SOUND within 15 days to avoid charges to your credit card. If such charges are incurred, the shipped part(s) will be billed at the then current price.

5. BAREFOOT SOUND will pay for shipping to and from the customer only within the first thirty days following the original product ship date. Following this 30-day period all shipping fees both for under warranty and post warranty repairs are the sole responsibility of the customer. The customer also assumes full liability for losses or damages resulting from shipping as well as all responsibility to pursue remuneration for such issues with their selected carrier.

## Post Warranty Repair

BAREFOOT SOUND accepts no liability for problems caused by after-market software or hardware modifications or additions. BAREFOOT SOUND is not responsible for any loss of work ("down time") caused by a product requiring service. This warranty is null and void if the defect or malfunction was due to damage resulting from operation not within manufacturer specifications. It will also

be null and void if there are indications of misuse and/or abuse. BAREFOOT SOUND has the option of voiding the warranty if anyone other than a BAREFOOT SOUND technician attempts to service the product. BAREFOOT SOUND will not warrant any problems arising from an act of God (lighting, flooding, tornado, etc.), electrical spikes or surges, or problems arising out of hardware, software, or additional devices added to complement any product

manufactured by BAREFOOT SOUND. Under no circumstances will BAREFOOT SOUND be responsible for any refund or remuneration exceeding the original purchase price of the product less any shipping fees. BAREFOOT

SOUND will not be held responsible for typographical errors on sales receipts, repair tickets, or on our website. BAREFOOT SOUND makes every effort to make sure all information on our website is correct.

## Warranty Exclusions

BAREFOOT SOUND accepts no liability for problems caused by after-market software or hardware modifications or additions. BAREFOOT SOUND is not responsible for any loss of work ("down time") caused by a product requiring service. This warranty is null and void if the defect or malfunction was due to damage resulting from operation not within manufacturer specifications. It will also be null and void if there are indications of misuse and/or abuse. BAREFOOT SOUND has the option of voiding the warranty if anyone other than an BAREFOOT SOUND technician attempts to service the product. BAREFOOT SOUND will not warrant any problems arising from an act

of God (lighting, flooding, tornado, etc.), electrical spikes or surges, or problems arising out of hardware, software, or additional devices added to complement any product manufactured by BAREFOOT SOUND. Under no circumstances will BAREFOOT SOUND be responsible for any refund or remuneration exceeding the original purchase price of the product less any shipping fees. BAREFOOT SOUND will not be held responsible for typographical errors on sales receipts, repair tickets, or on our website. BAREFOOT SOUND makes every effort to make sure all information on our website is correct.

## Maintenance

Exterior surfaces of this product may be cleaned using a non-abrasive lint-free cloth lightly dampened with water. Disconnect the mains power cable when cleaning to avoid risk of electric shock. Do not use alcohol-based cleaners. Driver active surfaces such as diaphragms and surrounds may be cleaned using dry soft bristle brushes. Driver diaphragms are very delicate and easily damaged. So, proceed with great care. Clean new sable artist brushes or cosmetic brushes work well for this task. Gently brush

dust away from the surface starting at the center of the driver diaphragm and moving radially outward. Avoid applying inward pressure to the driver diaphragm.

Repairs, maintenance, or other servicing of this product when its interior compartment is exposed should only be performed under specific advice from Barefoot Sound by a qualified technician or by the Barefoot Service Center. There are no user-serviceable parts inside this product.

## Technical Support and Service

Your Barefoot authorized dealer/distributor is usually the best resource for technical support regarding your specific application. You can also contact Barefoot Sound directly: [www.barefootsound.com/service-request/](http://www.barefootsound.com/service-request/)

[CLICK HERE FOR SERVICE](#)

**BAREFOOT**

**Barefoot Sound LLC**

[barefootsound.com](http://barefootsound.com)